

LIFE TABLE AND STOCHASTIC MATRIX PROJECTION ANALYSIS FOR A POPULATION OF GREEN IGUANAS (*IGUANA IGUANA*): IMPLICATIONS FOR CONSERVATION AND CONTROL

BRIAN C. BOCK^{1,4}, VIVIAN P. PÁEZ¹, A. STANLEY RAND², AND GORDON M. BURGHARDT³

¹Instituto de Biología, Universidad de Antioquia, AA 1226, Medellín, Colombia

²Smithsonian Tropical Research Institute, APO 0843-03092, Panamá, Republic of Panamá (Deceased)

³Department of Psychology and Department of Ecology and Evolutionary Biology, 1404 Circle Drive, University of Tennessee, Knoxville, Tennessee 37996-0900, USA

⁴Corresponding author, email: brianbock1@gmail.com

Abstract.—The Green Iguana (*Iguana iguana*) may be the most studied of all Neotropical squamate species. Given that many populations are over-exploited, and other introduced populations represent problems for native species, it is surprising that so few of the publications on the species have had a demographic focus. Here we resurrect data that formed the basis of previous publications on a population of Green Iguanas in Panamá that included female growth rates, nest site fidelity, and nesting migrations and hatchling growth rates and dispersal. We reanalyze these data from a demographic perspective, using a maximum likelihood modeling approach, to obtain estimates of survival for nesting females and hatchlings. These results, combined with available information on age at first reproduction, fecundities, and hatching success rates, permit us to construct a life table for this population that is concordant with information on its demographic tendencies (a 13.6% annual decline in number of nesting females). We then produce a stochastic projection matrix and conduct sensitivity and elasticity analyses to identify those vital rates that most influence the population growth rate. Both analyses suggest that survival rates during the first two to three years of life most strongly influence demographic tendencies. These results are interpreted both from the perspective of proposing management measures to help over-exploited iguana populations recover, and also to help control or eliminate introduced populations. We suggest that modifying hatchling and juvenile survival and growth rates would be a viable strategy for either augmenting or reducing Green Iguana population sizes.

Resumen.—La Iguana Verde (*Iguana iguana*) bien puede ser la especie más estudiada de todos los escamados neotropicales. Sin embargo, es sorprendente el reducido número de investigaciones que han tenido un enfoque demográfico, teniendo en cuenta que muchas de sus poblaciones son sobrecosechadas, y algunas poblaciones introducidas son consideradas problemáticas para las especies nativas. En este trabajo, resucitamos datos utilizados en publicaciones previas sobre las tasas de crecimiento ontogénico, fidelidad a los sitios de anidación y migraciones durante la estación reproductiva de las hembras reproductivas, así como información sobre la dispersión de neonatos de una población de iguana verde en Panamá. Reanalizamos estos datos desde un punto de vista demográfico, empleando modelos de máxima-verosimilitud, para obtener estimaciones de las tasas de sobrevivencia de hembras anidantes y los neonatos. Con estos resultados, y en combinación con la información disponible sobre la edad de reclutamiento, tasas de fecundidad y de eclosión de nidos, construimos una tabla de vida para las hembras, concordante con la tendencia demográfica de esta población (declive anual del 13,6% en el número de hembras anidantes). Adicionalmente, elaboramos una matriz de proyección poblacional estocástica, con la cual realizamos análisis de sensibilidad y elasticidad para identificar las tasas vitales que más afectan la tasa finita de crecimiento poblacional. Ambos análisis sugieren que las tasas de sobrevivencia anual de las primeras clases de edad (hembras de dos y tres años), son las transiciones que influyen más en las tendencias demográficas. Estos resultados son interpretados tanto desde la formulación de medidas de manejo para recuperar poblaciones en declive, como para controlar o eliminar poblaciones introducidas. Argumentamos que la modificación de las tasas de sobrevivencia de neonatos y juveniles y sus tasas de crecimiento ontogénico, son estrategias viables ya sea para aumentar o reducir los tamaños poblaciones de la Iguana Verde.

Key Words.—demography; Iguanidae; management; nesting aggregation; Panamá; sensitivity and elasticity analyses

INTRODUCTION

Thanks to its wide distribution and economic importance, the Green Iguana (*Iguana iguana*) is the best-studied species in the family Iguanidae, and perhaps even the best known of all Neotropical squamate species

(Bock 2014). Many Green Iguana populations are over-exploited (Fitch and Henderson 1977; Fitch et al. 1982; Stephen et al. 2011), but at the same time introduced populations outside of the natural range of distribution of the species are considered ecologically harmful to native fauna and flora (Smith et al. 2006, 2007; Meshaka et al.

2007; Garcia-Quijano et al. 2011; López-Torres et al. 2011; Pasachnik et al. 2012; Falcón et al. 2013). Yet there have been relatively few demographic studies conducted on this species.

Like most other species in the family Iguanidae, Green Iguanas exhibit a restricted annual nesting season (Wiewandt 1982), with mature females nesting only once each year. Evidence also suggests females nest every year after attaining sexual maturity (Bock et al. 1985; Rand and Bock 1992). Capture-mark-recapture studies of juveniles have documented declines in recapture rates during the first year of life (Henderson 1974; Harris 1982; van Devender 1982; Burghardt and Rand 1985), but without attempting to estimate what proportion of the decline was due to mortality, emigration, or changes in detectabilities with ontogenetic changes in habitat preferences. Finally, juvenile and adult Green Iguana densities have been estimated using different methods, including direct censuses (Dugan 1982; Rodda 1992) or analyses of capture-mark-recapture and transect data (Henderson 1974; Muñoz et al. 2003; Smith et al. 2007; López-Torres et al. 2011). But to date, a rigorous estimation of population age- or stage-specific demographic parameters has not been attempted, despite the need for such analyses to permit development of optimal management strategies for population recovery or control.

Here we resurrect data from studies initiated by ASR in the 1960s on a population of *Iguana iguana* in Panamá that investigated growth rates, nest site fidelity, and nesting migrations of females, as well as hatchling growth rates and dispersal (Burghardt 2004). We reanalyze these data from a demographic perspective, using a maximum likelihood modeling approach, to obtain estimates of annual survival rates of nesting females and weekly survival rates of hatchlings. These results, combined with available information on age at first reproduction, female fecundities, and nest hatching success rates, permit us to construct a life table for this population and produce stochastic projection matrices to conduct sensitivity and elasticity analyses. Our results may have implications both for management of recovering natural Green Iguana populations and control or elimination of exotic populations.

MATERIALS AND METHODS

Study site.—The study site was the Barro Colorado Nature Monument under stewardship of the Smithsonian Tropical Research Institute in Panamá, and specifically the portion of the iguana population associated with the Slothia communal nesting aggregation. Slothia is a small islet located approximately 20 m off the Barro Colorado Island (BCI) shoreline where ASR (1968) discovered a small artificial clearing where an estimated 150–200 female iguanas nested each February and

March. Gravid female iguanas were shown to migrate each year from BCI to Slothia (Bock et al. 1985, 1989) to nest communally, competing amongst each other for nest burrows (Rand and Rand 1976, 1978). The iguanas nesting on Slothia and inhabiting adjacent areas of BCI were intensively studied by ASR, GMB, and students during more than two decades, yielding over 30 publications on different aspects of the ecology and behavior of the species (Burghardt 2004).

Nesting female survival.—Studies of nesting female iguanas on Slothia were observational until 1980, when approximately 70% (65) of the gravid iguanas that visited the nesting clearing were captured by noosing them from a blind. They were measured, individually marked by systematically cutting crest scales, and released immediately. When all but 15 of these females were seen after their release as they continued to attempt to nest in the clearing, it was decided that the manipulation was not adversely affecting their behavior, so during the next four nesting seasons (1981–1984), an attempt was made to capture and mark all female iguanas that appeared at the aggregation each year. These data were analyzed to document nesting site fidelity (Bock 1984; Bock et al. 1985), adult female growth rates (Rand and Bock 1992), and annual survival rates (Rand and Bock 1992). However, annual survival was not rigorously estimated; rather, it was argued that the average annual return rate of 40% provided a minimum estimate of annual survival, given the evidence obtained from the simultaneous study of other nesting sites in the area indicating that female iguanas rarely changed nesting sites between years (Bock 1984; Bock et al. 1985).

Here we re-analyze these capture-mark-recapture data using a maximum-likelihood modeling approach using the software package MARK (White and Burnham 1999). We used the Cormack-Jolly-Seber model (Lebreton et al. 1992) to decompose the observed return rates of marked individuals into estimates of the two components of this parameter: apparent survival probability (Φ) and detection probability (p ; symbols follow Lebreton et al. 1992). We constructed an *a priori* candidate model set where Φ and p were either constant or variable over years. We also included models where Φ and p were constrained to exhibit increasing or decreasing trends over years. Finally, we used the initial snout-vent length (SVL) recorded for each nesting female as an individual covariate, to permit inspection of models where Φ was a function of female body size.

MARK uses information-theoretic methods to fit different candidate models to the data and uses probability theory to estimate the likelihood of each model (Anderson et al. 2000). It also permits the use of a multi-model approach, in which Akaike information indices (AIC) are used to compute weighted overall

estimates of Φ and p (Burnham and Anderson 1998). This model-averaging approach allows the simultaneous evaluation of various models, giving models with larger AIC weights greater influence on the overall model-averaged estimates of Φ and p .

Age at first reproduction.—During the 1982 and 1983 nesting seasons, the ultimate and penultimate phalanges of one digit were removed from a forefoot of each female iguana captured on Slothia, and also from females captured from other nearby nesting sites. Bones in these phalanges were prepared and examined to quantify the number of lines of arrested growth and marks of skeletal growth in the bone cross-sections, as a means of estimating the ages of these individuals (Zug and Rand 1987). Comparison of these skeletochronology estimates with the known encounter histories of the Slothia iguanas allowed corroboration of the estimates, and also provided data on the ages of those iguanas that were nesting on Slothia for the first time. Surprisingly, there was considerable variation in the estimated ages of first-nesting females in this sample (3–8 y of age). However, Zug and Rand (1987), like Rand and Bock (1992), assumed that because someone was present in the blind on Slothia during daylight hours during the entire nesting season each year, along with the evidence of limited inter-change among nesting sites by female iguanas from year to year, that the detectability at the Slothia nesting site was close to 1.0 (100% detection). Here, we use the mean of the detection probabilities estimated for 1982 and 1983 in the previous analysis ($= 0.55$) to adjust the distribution of ages at first nesting reported by Zug and Rand (1987). These adjustments recognize the possibility that almost half of the female iguanas assumed to be nesting for the first time by Zug and Rand (1987) may have actually nested undetected in a preceding year, and thus provide a more robust estimate of the ages at first reproduction of females in this population.

Fecundity.—Rand (1984) collected data on SVL and clutch size in 30 adult female iguanas obtained during the nesting season from different sites in central Panamá (but not BCI) and documented a significant positive relationship between these two variables. We used the regression equation from this study and the SVL of each female iguana captured on Slothia from 1980 to 1984 (first-capture measurements) to estimate mean clutch size and the range of clutch sizes oviposited on Slothia during the five years of this study.

Nest hatching success rate.—Two studies have used different methods to estimate nest hatching success rates at the Slothia nesting site. Rand and Dugan (1980) excavated the site immediately after hatchling emergence had ended and compared the number of slit-

opened egg shells (successfully incubated eggs) vs. number of eggs containing dead embryos or signs of having been opened by invertebrates (eggs that failed to hatch). They recognized that their estimate (21.5% egg mortality) was an under-estimate, because it failed to consider eggs that were oviposited and subsequently dug out by later nesting females using the same burrow system. Such eggs excavated onto the surface of the clearing were usually consumed by waiting vultures (Rand 1968; Sexton 1975).

Bock and Rand (1989) used the SVL measurements of nesting female iguanas during the 1981–1984 nesting seasons, along with the previously documented positive relationship between female SVL and clutch size (Rand 1984), to estimate the number of eggs laid on Slothia during these four years. They also quantified the number of eggs observed destroyed by being dug out onto the surface of the clearing. Finally, they fenced the nesting area before hatching began to attempt to capture all hatchling iguanas to emerge each year. Thus, they could calculate the percentage of all eggs oviposited each year that hatched, and also obtain an estimate of the percentage of laid eggs that were destroyed by other excavating females. Here, we used the mean percent of laid eggs that were destroyed from this study to adjust the earlier Rand and Dugan (1980) hatching success rate estimate, to yield five comparable estimates of the annual nest hatching success rate on Slothia.

Hatchling survivorship.—Several studies have captured and marked hatchling iguanas on Slothia and adjacent areas of BCI and attempted to recapture them to study their social group dynamics, growth rates (Burghardt and Rand 1985), and dispersal away from the nesting site (Drummond and Burghardt 1982; Bock 1984). Prior to 1983, all hatchlings were individually marked with toe clips, but in 1983 Bock (1984) individually marked hatchling iguanas by attaching different patterns of colored beads to plastic monofilaments pierced through the mid-dorsal flap of skin on their neck. Iguanas also were marked by painting 1 cm diameter spots on each side of the body with a paint that was dull during daylight hours, but reflected brilliantly when illuminated by artificial light at night (Rodda et al. 1988). A fence around the nesting area facilitated the capture of almost all hatchlings to emerge on Slothia that year (279 individuals captured, marked, and released).

On 44 nights during the seven weeks following the beginning of hatchling emergence on Slothia in 1983, 5 km of adjacent forested shoreline on BCI was searched from a boat at night with a spotlight in attempts to relocate the hatchlings as they dispersed to suitable juvenile habitat (low vegetation in open or riparian areas). This search distance was chosen based on data from the previous year of censusing that showed the

maximum dispersal distance of hatchlings from Slothia in either direction along the shoreline of BCI was 1.6 km (Bock 1984). On each night of censusing in 1983, vegetation in the nearby laboratory clearing on BCI also was searched on foot with a headlamp, to insure all available hatchling habitat was censused each night. The reflective paint facilitated detection of the marked hatchlings, and the bead marking technique had the advantage of permitting their identification without capturing and handling them (as is required with toe-clipped individuals), and often without even awakening them. This resulted in much higher recapture rates in 1983 as compared to comparable efforts in 1982 to monitor toe-clipped iguanas, where individuals were found to move higher in the vegetation to sleep on nights following their first recapture (Rodda et al. 1988).

During the 1983 censuses, unmarked hatchling iguanas that had emerged from other nesting areas also were found along the BCI shoreline and in the laboratory clearing. Ninety of these individuals also were captured, marked with beads and paint, and released so that their movements could be documented during subsequent nights of surveying. Here, we use these recapture data for the 1983 hatchlings marked on Slothia and BCI to compare the survival and detectability estimates of these pre- and largely post-dispersal individuals, using MARK. The *a priori* candidate model set contrasted models where Φ and p either were constant or variable over time (the seven sampling weeks) and were either identical or different for the Slothia and BCI individuals. Evidence of over-dispersion of the data under the fully parameterized model (site and time differences in Φ and p) was addressed by adjusting \hat{c} to 2.4 for subsequent analyses. Again, parameter estimates were obtained by model averaging.

Life table approximation.—Green Iguanas reproduce annually (Rand and Greene 1982; Bock et al. 1985; Rand and Bock 1992), so we constructed an age-based life table, with the exception of dividing the first year of life into three separate stages (egg incubation, hatchling dispersal period, and post-dispersal period). There are estimates available for most of the elements of this life table, but we lack estimates for several key transitions. For example, the weekly post-dispersal survivorship rate estimated for the 1983 BCI hatchlings was clearly unsustainable (because almost no hatchlings would attain 1 y of age with that level of weekly mortality). Numerous studies have mentioned the massive mortality hatchling iguanas suffer immediately following emergence (Henderson 1974; Harris 1982; van Devender 1982; Burghardt and Rand 1985; Knapp and Abarca 2009), both because hatchlings are especially vulnerable to predators while they are dispersing (Greene et al. 1978) and because predators congregate in hatchling habitat at this time of year (Drummond and Burghardt

1982). But once hatchlings have settled, their survival probability presumably increases over time, both because predators disperse once hatchling densities are depleted, and because hatchlings are vulnerable to a smaller suite of predators as they grow (Greene et al. 1978). Unfortunately, the mortality they suffer during their first year following dispersal makes the rigorous estimate of post-dispersal survival using capture-mark-recapture methods impossible, due to the sparse recaptures.

The other two parameters for the Green Iguana life table that we cannot estimate from available data are sub-adult (1–2 y of age) and non-reproductive adult (age > 2 y) annual survival rates. As iguanas grow, they move higher into the vegetation (Hirth 1963; Henderson 1974), making it even more difficult to study their survival rates using capture-mark-recapture methods. Also, the Zug and Rand (1987) data indicated that female iguanas begin to nest at different ages, and while we were able to estimate annual survival rates for reproductive adult females, non-reproductive females of the same age likely enjoy higher survival because they do not suffer the energetic costs and risks associated with producing clutches (Rand 1984), migrating to and from the nesting site (Bock et al. 1989), and constructing a nest (Rand and Rand 1976, 1978; Dugan et al. 1981). Thus, to produce a complete life table, we made the assumptions that non-reproductive adult female annual survival was higher than the reproductive female annual survival rate we estimated, and also that it was higher than sub-adult survival, which in turn was higher than survival rates for post-dispersal hatchling iguanas. Finally, we selected transition probabilities for the proportion of non-reproductive females to become reproductive in the next age class so as to generate a distribution of ages for first-nesting females similar to the distribution of adjusted estimates obtained from Zug and Rand (1987).

One approach to completing the life table would be to assume this protected Green Iguana population was at its carrying capacity and not changing in density, and then ask the question of what values for the three un-estimated parameters would produce a life table that yields a stable population size ($\lambda = 1$)? However, while there was no evidence that iguana densities on BCI were changing during the study period, the number of female iguanas using the Slothia nesting site was declining. In the 1960s, an estimated 150–200 females nested there annually (Rand 1968), but when it was perceived that fewer iguanas were nesting there each year, a monitoring program was initiated in 1972, consisting of enlisting a resident of BCI each year to observe the nesting clearing on Slothia through a telescope from the front porch of the BCI dormitory building each day around midday. Each year from 21 January to 17 March (spanning the entire nesting season) the number of nesting females visible in the clearing was recorded on most days,

producing a remarkable but unpublished dataset spanning a 26 y period (1972–1997).

Here, we calculated the daily mean number of female iguanas observed in the clearing on Slothia for each year of monitoring and used linear regression on the natural log transformed values to estimate the intrinsic rate of increase of the population (r), and calculated λ as e^r . We then completed the life table by determining the values for the three un-estimated parameters that would produce a population of nesting females on Slothia that was declining at the same rate ($\lambda < 1$), in the following manner.

First, we constrained the life table so that non-reproductive adult female annual survival was greater than 0.58 (the mean reproductive female annual survival rate, see Results below). To reflect how survival increases as iguanas grow, we set sub-adult (1–2 y of age) annual survival to 0.50 of the non-reproductive adult female rate, and post-dispersal hatchling survival for the months until they completed their first year of life at 0.50 of the sub-adult rate. We then assigned potential values for non-reproductive female survival (and hence also for sub-adult and post-dispersal hatchling survival) in an interpolative fashion until values were obtained that yielded approximately the correct value of λ .

We then converted this life table into a 9 X 9 Leslie matrix by collapsing the first three stage classes (eggs, pre-dispersal hatchlings, and post-dispersal hatchlings) into a 0–1 y age class, and also combined the non-reproductive and reproductive adult female classes for the 2–3 to 7–8 y age classes. This annual demographic matrix yielded a mathematical representation of the life-cycle, where all transitions among, and reproductive contributions of, each age class may be observed in yearly time steps, with each column corresponding to one year in the life of a female iguana. The first row of the matrix represents effective fecundity values of different aged females (F_x) and diagonal elements represent between-age class progressions (G). F_x is the average number of female hatchlings produced during a year by an average female from the corresponding adult age category. We calculated these age-specific effective fecundities employing the equations of Caswell (2001) for a birth-pulse population with post-breeding censuses, as: $F_x = (G_{x-1}) (m_x)$; where F_x is the effective fecundity for age class x , G is the progression (survival until progression to a larger age class is achieved), and m_x representing the number of female eggs a female lays in a year for age class x .

Finally, we incorporated stochasticity into the projection to reflect effects of environmental variability by allowing population vital rates to vary each year. The way we estimated the mean fecundity rate and established the range of possible values around this mean, as well as the mean annual survival rates and ranges of permissible values around those means for all age classes, are described in the Results section. In the

stochastic projection, we randomly sampled from a triangular distribution around these means for these vital rates, where the range of possible random numbers were distributed between the minimum and maximum estimated rates. This permitted the calculation of confidence intervals for model results on the stable age distribution (SAD), λ_S (the stochastic finite rate of population growth), reproductive values (RV), and sensibilities and elasticities, using the Monte Carlo feature of PopTools add-in for Microsoft® Excel software (G.M. Hood. 2010. PopTools v3.2.5. Available from <http://www.poptools.org> [Accessed 13 January 2015]) with 40 iterations. λ_S is the long-term projected rate of change for a population governed by this Leslie matrix with environmental stochasticity. RVs represent the relative contribution of individuals within an age class to current and future reproduction (Fisher 1930) and are derived from the combination of estimates of age-specific survival and current and future potential fecundity (Wallace et al. 2008). Sensitivity analyses measure the absolute change in λ if an absolute value of a particular vital rate in the matrix is modified while holding all other values constant, while elasticity analyses are the proportional sensitivities of λ to proportional changes in vital rates within the matrix (Caswell 2001).

RESULTS

Nesting female survival.—The AIC rankings of the models in the candidate model set are presented in Table 1. There was no support for models that examined the possibility that apparent survival was related to the body sizes of the nesting iguanas. The best-supported model was the one that included a trend over years for both survival rates and detection probabilities, with the former increasing and the later decreasing over time. Model-averaged estimates for these annual parameters are presented in Table 2. The mean annual survival rate

TABLE 1. AIC rankings for the nine candidate models examined with the nesting female Green Iguana (*Iguana iguana*) capture-mark-recapture data from the Slothia nesting site on Barro Colorado Island, Panamá. Φ represents apparent annual survival rate and p represents detection probability. A period in the model specification denotes constancy over time, Time represents variation over time, and Trend represents a unidirectional change over time. Models with SVL examined how body size influenced Φ .

Model	AIC _c	Delta AIC _c	AIC _c weight	Number of parameters
$\Phi(\text{Trend})p(\text{Trend})$	354.0	0.0	0.57	4
$\Phi(.)p(.)$	356.1	2.1	0.18	2
$\Phi(\text{Time})p(\text{Trend})$	358.0	4.0	0.07	6
$\Phi(\text{Trend})p(\text{Time})$	358.0	4.0	0.07	6
$\Phi(\text{Time})p(.)$	358.6	4.6	0.05	5
$\Phi(./\text{SVL})p(.)$	359.0	5.0	0.04	2
$\Phi(\text{Time})p(\text{Time})$	360.0	6.0	0.03	7
$\Phi(.)p(\text{Time})$	360.2	6.2	0.02	2
$\Phi(./\text{SVL-SVL2})p(.)$	361.0	7.0	0.02	5

TABLE 2. Model-averaged estimates of apparent annual survival rates (Φ) and detection probability (p) of nesting female Green Iguanas (*Iguana iguana*) at the Slothia nesting site on Barro Colorado Island, Panamá. Models that included the individual covariate (SVL) were not included in the weighted averages.

	Weighted average	Standard error	Lower 95% confidence interval	Upper 95% confidence interval
1980–1981 Φ	0.434	0.063	0.278	0.610
1981–1982 Φ	0.592	0.070	0.426	0.739
1982–1983 Φ	0.700	0.104	0.338	0.908
1981 p	0.738	0.075	0.446	0.913
1982 p	0.624	0.073	0.454	0.768
1983 p	0.476	0.082	0.252	0.710
1984 p	0.359	0.083	0.096	0.747

of reproductive adult females (1980–1983) was 0.575, with a range of 0.434–0.700. We assume that survival varies from year to year in a comparable way for both reproductive and non-reproductive adult females, so applied this same range around the mean annual survival rate estimate for the combined non-reproductive and reproductive adult female age classes in the stochastic matrix projection analysis.

Age at first reproduction.—Even after accounting for the possibility that some of the iguanas assumed by Zug and Rand (1987) to be nesting on Slothia for the first time had actually nested undetected the previous year, there was a surprisingly wide range in the adjusted estimated ages at first nesting (Table 3). Female iguanas apparently first nest from 2–8 y of age, with the modal age being 4–5 y old. The maximum age for a reproductive female in this sample was 9 y old (Zug and Rand 1987).

Fecundity.—Estimated clutch sizes of female iguanas captured on Slothia from 1980 to 1984 averaged $44.2 \pm$ (SD) 6.8 eggs/clutch (range, 25.5–59.7 eggs/clutch; all five years, $n = 165$). Because clutch size and age are not correlated in Green Iguanas (Zug and Rand 1987) and sex is determined by heterogametic sex chromosomes (Rovatsos et al. 2014), in the life table we set the fecundities of all reproductive females to 22.1 “female eggs”/y ($44.2/2$) and used the range of 12.8–29.9 for the stochastic matrix analysis.

Nest hatching success rate.—In 1981, which was the wettest year in over 85 years of data for this area of Panamá, a single clutch of 25 atypically small neonates emerged one month later than the normal onset of hatchling emergence on Slothia. Since an estimated 1,780 eggs were oviposited that year, the estimated hatching success rate was only 1.4%. Hatching success rates in 1982, 1983, and 1984 were 27.0%, 34.0%, and 46.2%, respectively. Given that approximately 22% of the eggs laid on Slothia from 1981 to 1984 were dug out onto the surface by other nesting iguanas, the adjusted

TABLE 3. Estimates of the ages of Green Iguanas (*Iguana iguana*) nesting for the first time at the Slothia nesting site on Barro Colorado Island, Panamá, based upon an adjustment of the data presented by Zug and Rand (1987) using the mean of the detection probabilities (p) estimated for 1982 and 1983.

Age at first nesting	Number of individuals reported by Zug and Rand (1987)	Adjusted number of individuals	Percentage of the total
2	-	0.45	1.3%
3	1	4.60	13.3%
4	9	9.45	27.0%
5	10	9.10	26.0%
6	8	7.10	20.3%
7	6	3.75	10.7%
8	1	0.55	0.6%

hatching success rate from the Rand and Dugan (1980) study was 64.1%, for a mean hatching success rate over these five years of 34.5%, and a mean hatching success rate over the four “typical” years (1981 excluded) of $42.8 \pm 16.2\%$ (range, 27.0–64.1%).

Hatchling survival.—Nineteen percent of the 279 hatchling iguanas captured, marked, and released on Slothia in 1983 were recaptured on BCI in one or more subsequent weeks, and 56% of the 90 hatchlings first captured on BCI also were recaptured in subsequent weeks. The AIC rankings of the 10 models in the candidate model set are presented in Table 4. It is important to bear in mind that these are weekly survival estimates, with the most supported model showing a lower apparent survival estimate for the pre-dispersal Slothia individuals, although the apparent survival of the largely post-dispersal individuals first captured on BCI also was low (Table 5). Also, the model indicated that detectability of the pre-dispersal Slothia individuals was lower than that of the individuals first marked on BCI (Table 5).

TABLE 4. AIC rankings for the ten candidate models examined with the hatchling Green Iguana (*Iguana iguana*) capture-mark-recapture data from 1983. Φ represents apparent weekly survival rate and p represents detection probability. Site refers to a difference between pre-dispersal hatchlings marked on Slothia vs. largely post-dispersal hatchlings marked on Barro Colorado Island, Panamá. A period in the model specification denotes constancy over time, and Time represents variation over time.

Model	AIC _c	Delta AIC _c	AIC _c weight	Number of parameters
$\Phi(\text{Site})p(\text{Site})$	348.6	0.0	0.485	4
$\Phi(\text{Site})p(.)$	349.7	1.1	0.287	3
$\Phi(.)p(\text{Site})$	350.2	1.6	0.224	3
$\Phi(\text{SiteTime})p(.)$	359.1	10.5	0.001	13
$\Phi(.)p(.)$	361.5	12.9	0.001	2
$\Phi(\text{Time})p(\text{SiteTime})$	363.5	14.9	< 0.001	17
$\Phi(\text{SiteTime})p(\text{Time})$	366.2	17.6	< 0.001	17
$\Phi(\text{Time})p(\text{Time})$	367.0	18.4	< 0.001	11
$\Phi(\text{SiteTime})p(\text{SiteTime})$	369.2	20.6	< 0.001	22
$\Phi(.)p(\text{SiteTime})$	370.2	21.6	< 0.001	7

TABLE 5. Model-averaged estimates of apparent weekly survival rates (Φ) and detection probabilities (p) of hatchling Green Iguanas (*Iguana iguana*) marked at the Slothia nesting site (pre-dispersal) or marked on Barro Colorado Island (BCI; largely post-dispersal).

	Weighted average	Standard error	Lower 95% confidence interval	Upper 95% confidence interval
Slothia hatchling Φ	0.471	0.060	0.316	0.631
BCI hatchling Φ	0.650	0.067	0.470	0.796
Slothia hatchling p	0.393	0.081	0.204	0.621
BCI hatchling p	0.604	0.091	0.372	0.799

Life table approximation.—Nesting iguana monitoring data were collected for Slothia on an average of 41.2 d during the 57-d observation period each year, over the 25 y for which data were available (monitoring data from the 1982 nesting season were lost). Regression of Ln (mean number of iguanas seen per day) against the year of the study (-1900) revealed a significant negative relationship ($F = 33.7$, $df = 22$, $P < 0.001$; Fig. 1), with a slope (r) of -0.146, which yielded an estimate of $\lambda = e^r = 0.864$.

As explained above, our estimates for the life table analysis for the range in fecundities was approximately ± 8.6 female eggs/clutch around the mean of 22.1 female eggs/clutch, and the range of adult reproductive survival rates was approximately ± 0.133 around a mean annual survival rate of 0.575 for the 8–9 y old age class where all individuals reproduced. We also set this same range around higher annual survival rates in earlier age classes composed of both reproductive and non-reproductive adult females. But we lacked means to estimate the annual extent of variation around our estimates for the composite 0–1 y age class and our derived 1–2 y age

class. We therefore arbitrarily set the ranges around the mean survival rates for these age classes to ± 0.013 and ± 0.133 , respectively (Table 6).

We found that a post-dispersal hatchling survivorship of 0.194, a sub-adult iguana survivorship of 0.387, and a non-reproductive female survivorship of 0.774 yielded a life table that exhibited a 13.6% annual decline ($\lambda = 0.864$). The different components of this female iguana life table are diagrammed in Fig. 2A. Upon pooling the first three stages of the life cycle into a 0–1 y age class and combining non-reproductive and reproductive females in the same age classes (diagrammed in Fig. 2B) and projecting the matrix until it attained an SAD with a $\lambda = 0.864$, the corresponding 9 X 9 Leslie matrix was generated (Fig. 3). After 40 iterations, the projected stochastic finite rate of increase from the Monte Carlo simulation was $\lambda_S = 0.806$ ($SD = 0.176$).

The sensitivity and elasticity values of each transition produced by this projection differed in similar ways. In the sensitivity analysis, the progression from the 0–1 y age class to the 1–2 y age class produced the greatest absolute change in λ , followed by the 1–2 y old to 2–3

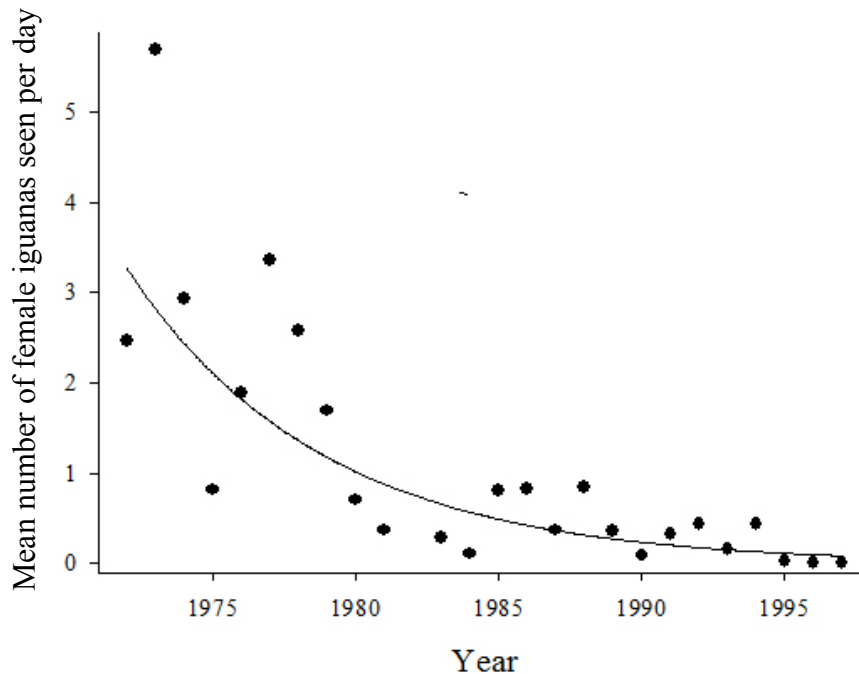

FIGURE 1. Decline in the mean daily number of nesting Green Iguanas (*Iguana iguana*) seen in the clearing on the Slothia nesting site on Barro Colorado Island, Panamá from 1972–1997, when nesting activity on Slothia had ended. Mean number of iguanas seen daily = $12.22 + -0.13 X (y-1900)$.

TABLE 6. Demographic parameters for female Green Iguanas (*Iguana iguana*) from the Slothia nesting aggregation in Panamá. F_x is the effective fecundity for age class x , G is the progression (survival until progression to the next age class is achieved), and m_x representing the number of female eggs a female lays in a year for age class x . Ranges for G_x used in the stochastic projection are in parentheses.

Age class	n_x	Probability of reproduction	m_x	G_x	F_x	SAD	RV
0–1	1,000	0	0	0.039 (0.026–0.040)	0	0.849	1.00
1–2	38.924	0	0	0.387 (0.254–0.520)	0	0.044	20.02
2–3	15.064	0.010	22.1	0.973 (0.820–1.000)	0.008	0.019	34.02
3–4	14.663	0.085	22.1	0.757 (0.544–0.810)	0.154	0.022	27.94
4–5	11.109	0.252	22.1	0.725 (0.523–0.789)	1.062	0.019	30.96
5–6	8.055	0.441	22.1	0.688 (0.499–0.765)	3.116	0.016	29.91
6–7	5.546	0.717	22.1	0.634 (0.466–0.732)	7.825	0.012	31.77
7–8	3.521	0.931	22.1	0.593 (0.441–0.707)	12.160	0.009	27.53
8–9	2.089	1.000	22.1	0	13.11	0.006	16.54

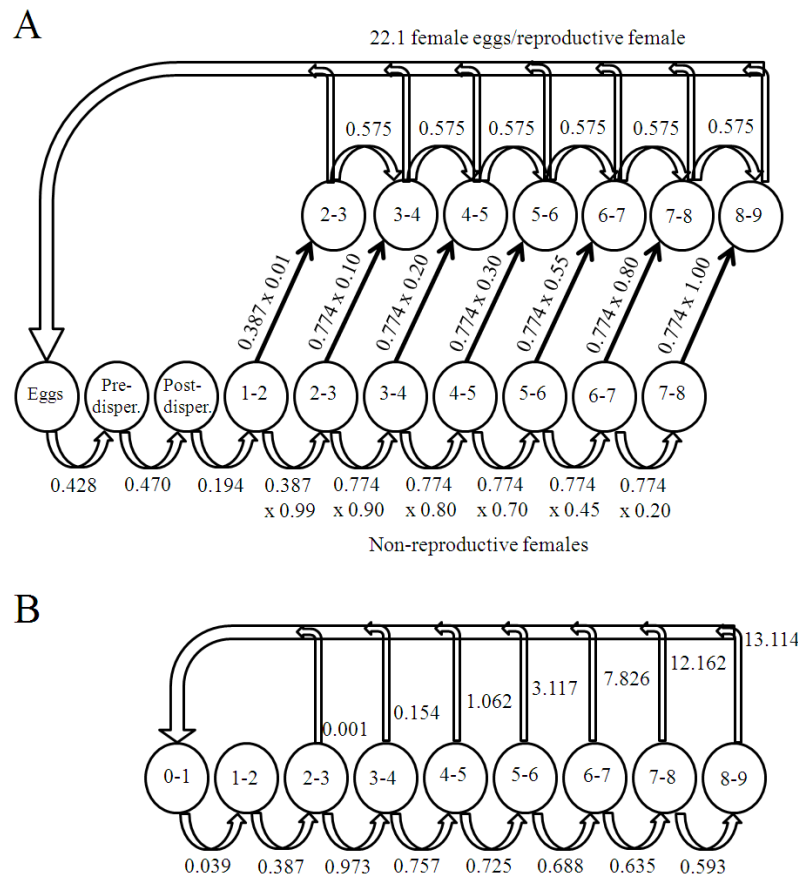

FIGURE 2. (A) Diagram of the female Green Iguana (*Iguana iguana*) life cycle based on data from the Slothia nesting site on Barro Colorado Island, Panamá, showing transition probabilities and reproductive contributions of the different age classes. (B) Diagram of the annual life cycle after pooling the initial three stages into the 0–1 y age class and combining reproductive and non-reproductive female categories. This diagram summarizes the values obtained from the projection analysis that attained a stable age distribution with $\lambda = 0.864$. Circles are age classes, curved arrows connecting circles are transition rates among age classes, diagonal arrows are transition rates from non-reproductive to reproductive status, and vertical arrows are age-specific fecundities.

year old survival probability (Fig. 4A). Similarly, in the elasticity analysis the highest values were for survival (progression rates) of young, primarily pre-reproductive females (from 1–4 y old), followed by progression rates of older females (from 5–7 y old). The relative importance of fecundity for population growth rate was much lower (summed elasticity values = 0.13). When the elasticity values of progression from young females are combined (1–4 y old classes), they represent 0.52 of the overall demographic effects on population growth. The projected trajectory of this *I. iguana* population based upon these vital parameter estimates predicted the local extinction of the population in 20 y.

DISCUSSION

The two previous studies that yielded demographic parameters useful for our analysis in this study were both surprising. First, Zug and Rand (1987) provided evidence that the age at first nesting in female Green Iguanas varies considerably. Most demographic studies of reptile species establish the minimum size or age at first reproduction from a sample of individuals (using histology or capture-mark-recapture data) and then

assume most individuals in the population begin reproducing at or near this point. This assumption usually is reasonable, given the expectation that natural selection should rapidly eliminate any variation around the optimal timing of reproductive maturation, given the important fitness consequences of this trait. The evidence that female Green Iguanas may first nest at anywhere from 2–8 y of age (Zug and Rand 1987) is therefore remarkable, and it implies that the source of this large variance must have an environmental basis (rather than reflecting genetic differences; e.g., Andrews 1989).

Growth rate data on maturing female iguanas are lacking, but Burghardt and Rand (1985) showed that growth rates in hatchling iguanas were highly variable, but averaged 0.31 mm SVL/d over the first few months of life (which translates into a rate of 133 mm SVL/y). In contrast, female Green Iguanas grow very little each year after they begin to nest (mean = 6.8 mm SVL/y; Rand and Bock 1992). If an averaged sized (72 mm SVL) hatchling iguana were able to maintain a mean initial growth rate of 0.31 mm SVL/d for a period of two years, it would be able to attain the minimum size at first reproduction (295 mm SVL) in less than two years, as do female iguanas maintained on supplemented diets in captivity (Werner 1991). However, growth rates in maturing juvenile iguanas surely decline over time. Presumably, in the wild, the few female iguanas that are able to reproduce at 2–3 y of age are those that had significantly above-average initial growth rates, and that they were able to remain above-average during their ontogeny as their growth rates slowed. So while the available growth rate data for pre-reproductive iguanas are limited, they are consistent with the conclusion of Zug and Rand (1987) that most female iguanas nest for the first time at four years of age or older.

The other surprising result from a previous study used in this analysis was the evidence from Rand and Bock (1992) that reproductive female iguana annual survival rates were so low. An annual survival rate of only 0.58 means that most reproductive females only nest once or twice in their lives. Combined with the evidence for the relatively late maturation in many female iguanas, it also implies a substantial number of female iguanas that attain two years of age never nest at all. However, the Cormack-Jolly-Seber model employed in the analyses of the Slothia female iguana capture-mark-recapture data actually estimates “apparent survival”, because it is not able to distinguish between disappearances due to mortality vs. emigration.

In an effort to document rates of cross-over among nesting sites, 177 nesting female iguanas were trapped at alternate nesting sites around Slothia in 1981–1984 (Bock 1984; Bock et al. 1985). The pattern that emerged was that once a female iguana began using a nesting site, she tended to return to that site in all subsequent years until her presumed death, or until the study ended.

$$A = \begin{pmatrix} 0.000 & 0.000 & 0.008 & 0.154 & 1.062 & 3.116 & 7.825 & 12.16 & 13.11 \\ 0.039 & 0.000 & 0.000 & 0.000 & 0.000 & 0.000 & 0.000 & 0.000 & 0.000 \\ 0.000 & 0.387 & 0.000 & 0.000 & 0.000 & 0.000 & 0.000 & 0.000 & 0.000 \\ 0.000 & 0.000 & 0.973 & 0.000 & 0.000 & 0.000 & 0.000 & 0.000 & 0.000 \\ 0.000 & 0.000 & 0.000 & 0.757 & 0.000 & 0.000 & 0.000 & 0.000 & 0.000 \\ 0.000 & 0.000 & 0.000 & 0.000 & 0.725 & 0.000 & 0.000 & 0.000 & 0.000 \\ 0.000 & 0.000 & 0.000 & 0.000 & 0.000 & 0.688 & 0.000 & 0.000 & 0.000 \\ 0.000 & 0.000 & 0.000 & 0.000 & 0.000 & 0.000 & 0.634 & 0.000 & 0.000 \\ 0.000 & 0.000 & 0.000 & 0.000 & 0.000 & 0.000 & 0.000 & 0.593 & 0.000 \end{pmatrix}$$

FIGURE 3. 9 × 9 Leslie matrix of the female Green Iguana (*Iguana iguana*) life cycle based on data from the Slothia nesting site on Barro Colorado Island, Panamá.

A

$$S = \begin{pmatrix} 0.000 & 0.000 & 0.003 & 0.004 & 0.004 & 0.004 & 0.003 & 0.002 & 0.002 \\ 2.698 & 0.000 & 0.000 & 0.000 & 0.000 & 0.000 & 0.000 & 0.000 & 0.000 \\ 0.000 & 0.224 & 0.000 & 0.000 & 0.000 & 0.000 & 0.000 & 0.000 & 0.000 \\ 0.000 & 0.000 & 0.106 & 0.000 & 0.000 & 0.000 & 0.000 & 0.000 & 0.000 \\ 0.000 & 0.000 & 0.000 & 0.132 & 0.000 & 0.000 & 0.000 & 0.000 & 0.000 \\ 0.000 & 0.000 & 0.000 & 0.000 & 0.127 & 0.000 & 0.000 & 0.000 & 0.000 \\ 0.000 & 0.000 & 0.000 & 0.000 & 0.000 & 0.154 & 0.000 & 0.000 & 0.000 \\ 0.000 & 0.000 & 0.000 & 0.000 & 0.000 & 0.000 & 0.089 & 0.000 & 0.000 \\ 0.000 & 0.000 & 0.000 & 0.000 & 0.000 & 0.000 & 0.000 & 0.044 & 0.000 \end{pmatrix}$$

B

$$E = \begin{pmatrix} 0.000 & 0.000 & 0.000 & 0.000 & 0.006 & 0.018 & 0.031 & 0.041 & 0.034 \\ 0.131 & 0.000 & 0.000 & 0.000 & 0.000 & 0.000 & 0.000 & 0.000 & 0.000 \\ 0.000 & 0.131 & 0.000 & 0.000 & 0.000 & 0.000 & 0.000 & 0.000 & 0.000 \\ 0.000 & 0.000 & 0.131 & 0.000 & 0.000 & 0.000 & 0.000 & 0.000 & 0.000 \\ 0.000 & 0.000 & 0.000 & 0.131 & 0.000 & 0.000 & 0.000 & 0.000 & 0.000 \\ 0.000 & 0.000 & 0.000 & 0.000 & 0.124 & 0.000 & 0.000 & 0.000 & 0.000 \\ 0.000 & 0.000 & 0.000 & 0.000 & 0.000 & 0.106 & 0.000 & 0.000 & 0.000 \\ 0.000 & 0.000 & 0.000 & 0.000 & 0.000 & 0.000 & 0.075 & 0.000 & 0.000 \\ 0.000 & 0.000 & 0.000 & 0.000 & 0.000 & 0.000 & 0.000 & 0.034 & 0.000 \end{pmatrix}$$

FIGURE 4. (A) S matrix = results of the sensitivity analysis. (B) E matrix = results of the elasticity analysis. Both were based on the stochastic projections of the 9 X 9 Leslie matrix of the female Green Iguana (*Iguana iguana*) life cycle based on data from the Slothia nesting site on Barro Colorado Island, Panamá.

Nesting site fidelity was not absolute, however. On 13 occasions, a female iguana marked on Slothia failed to return in the following year, but nested on Slothia again in a subsequent year. These iguanas would impact the Cormack-Jolly-Seber analyses by decreasing estimates of detectabilities, and although relatively few iguanas skipped years on Slothia, the trend in decreasing detectabilities over the course of the study indicates that with each subsequent year of capturing effort on Slothia, the tendencies of the females to skip years increased. Female iguanas that skipped nesting seasons on Slothia did not grow more than females that nested on Slothia the year they were absent, so we assume they nested elsewhere undetected. However, only one instance of genuine cross-over between Slothia and another established nesting site was documented (a female marked on Slothia was recaptured at another site located approximately 1 km distance from Slothia in one nesting season, but returned to nest again on Slothia the following year). These results support the conclusion that most of the disappearance of reproductive females from the Slothia nesting site was actually due to mortality rather than emigration.

There also was additional evidence suggesting that mortality rates in the reproductive females captured on Slothia were high. Two individuals were observed being killed during the study by a nest-guarding female American Crocodile (*Crocodylus acutus*) that also nested in the clearing on Slothia each year (Dugan et al. 1981; Bock and Rand 1989). Also, 37% of the female iguanas on Slothia had regenerating tails on first capture, and 27% of the recaptured females lost portions of their complete or already regenerating tails in the interval between being first marked and recaptured. Finally, the fact that the oldest nesting iguana in the Zug and Rand (1987) skeletochronology study was only 9 y old, when longevity in Green Iguanas in captivity is approximately 20 y (Castanet 1994; Slavens and Slavens 1999), argues that mortality rates in adult females in the wild are high.

Thus, we were obliged to construct a life table for the Slothia Green Iguana nesting aggregation that included variable ages at first nesting and relatively high reproductive female annual mortality rates. The model also included other estimates of demographic parameters available in previous publications on this population and we also made certain assumptions concerning how survival rates must increase as female iguanas grow early in life, to produce a biologically plausible life table consistent with the independent monitoring data indicating this population was in decline.

The demise of the Slothia nesting aggregation might be considered surprising, since early publications on this site stressed its advantage of lacking terrestrial nest predators common on BCI (Rand and Robinson 1969; Drummond 1983). But costs associated with nesting in aggregation that also were documented on Slothia

included the need for females to compete with each other for partially-completed nest burrows (Rand and Rand 1976, 1978), the risk of having nests disturbed by subsequent excavating females (Sexton 1975; Rand and Dugan 1980), and the risk of predation from the nest-defending American Crocodile (Dugan et al. 1981; Bock and Rand 1989).

The 30-year decline in numbers of nesting female iguanas on Slothia was not due to the manipulation of capturing females there, because the trend began well before and continued after this five-year period of intensive study. The decline also was not due to successional habitat changes altering the suitability of the site for nesting, because ASR periodically cut back vegetation that encroached into the artificial clearing where iguanas nested. Capture-mark-recapture data on nesting female iguanas (Bock 1984) also indicated that the decline was not due to adult females abandoning the site in preference for other areas, despite the fact that alternative nesting areas were available. During the five years of intensive capturing study on Slothia, well-established alternate sites were available 2 km distance from Slothia, and in 1981 a construction project on BCI near Slothia created a new open area suitable for nesting. In 1993, an even larger perturbation in the same location produced a permanent open clearing as the new laboratory, dining, and residence facilities on BCI were constructed. Finally, several atypical nesting sites on small islands adjacent to BCI have been discovered where iguanas nest in the forest in sites where tree falls or other disturbances have produced gaps in the canopy (Bock et al. 1998). We suspect that the decline in numbers of nesting females on Slothia was due to reduced recruitment of newly matured females to this site as they opted to nest in these alternative areas. Thus, our estimates of “apparent survival” of pre-reproductive females in our model may be under-estimates of true survival rates because they combine true mortality with this emigration of iguanas that hatched on Slothia, but that selected alternative nesting sites when they matured.

Our life table for *Iguana iguana* differs considerably from the few others available for other species in the Family Iguanidae (Chuckwalla, *Sauromalus ater*, Abts 1987; Turks and Caicos Rock Iguana, *Cyclura carinata*, Iverson 1979; Allen Cays Rock Iguana, *Cyclura cyclura inornata*, Iverson 2007), with Green Iguanas exhibiting lower juvenile and adult survival rates, shorter times to maturity (with respect to *Cyclura*), shorter life spans, and larger clutch sizes. Wiewandt (1982) argued that climate and predator pressures were the primary determinants in the evolution of life history differences in the Iguanidae, and while our results generally support these ideas, it is clear there is a need for more life table studies on additional iguana species in order to more rigorously test hypotheses on life history evolution in this family.

There is also a need for more intra-specific studies, because life history characteristics of a population may vary greatly depending upon whether it is stable, declining locally due to over-exploitation, or expanding in areas outside its natural range of distribution. While we recognize the limitations inherent in generalizing from one population to another, we still believe that, lacking more information from other populations, the female Green Iguana life table and projection matrix we constructed may have relevance for other iguana populations.

The BCI iguana population on which this study was based was protected from poaching, but most natural iguana populations experience harvests that specifically target nesting females (Fitch and Henderson 1977; Fitch et al. 1982; Stephen et al. 2011). The sensitivity analysis we conducted indicated that the most effective means to increase λ in our population would have been to raise survival rates during the first two years of life, while the elasticity analyses highlighted the importance of survival during the first four years of life. While it might seem complicated to implement predator control programs or other intensive management strategies such as headstarting to increase juvenile survival rates, thanks to their unique biology, this might not be necessary for Green Iguanas. Body size is correlated with age in young Green Iguanas, but they grow at variable rates (Burghardt and Rand 1985; Werner 1991) and their growth trajectories seem to asymptote at very different SVLs, so that in nesting females, age is no longer correlated with body size (Zug and Rand 1987). But faster growing hatchling and juvenile iguanas suffer lower predation rates (Greene et al. 1978), meaning that by increasing their growth rates, their survival also would increase. For example, Werner (1991) divided 12 pairs of captive-reared sibling female Green Iguanas into control (natural diet) and experimental (enhanced diet) groups for the first seven months of life, and produced a 32% difference in body mass between groups. Only one of the 12 control females reproduced at two years of age, while half of the experimental group nested at this age. Obviously, enhancing juvenile growth rates in over-exploited Green Iguana populations holds great promise for altering their demographics so they may better withstand harvests. Planting optimal diet items in juvenile habitat is one possible strategy, and inoculating hatchlings with microbial gut faunas that have been shown to spur growth is another (Troyer 1984a, b).

Our life table and projection matrix also might be applicable to exotic Green Iguana populations in need of control, for example where an exotic population has reached its carrying capacity and females are emigrating in search of less crowded nesting sites, thereby expanding the range of the introduction. As before, it could be by altering juvenile survival rates that the demographics of such a population might best be managed. And again, one need not contemplate intensive juvenile eradication

projects. There are other means to lower hatchling and juvenile growth rates, and thereby their survival rates and perhaps also increase their ages at first reproduction, that also are based upon their herbivory and associated gut microbial faunas. Wikelski et al. (2002) documented a 60% decline in Marine Iguana (*Amblyrhynchus cristatus*) densities following a minor oil spill that lightly covered the algae that these iguanas consume. The iguanas did not die immediately, but apparently starved to death with full stomachs after losing their microbial gut faunas, and hence their ability to digest their food. Such a light application on the vegetation of some environmentally innocuous agent capable of deactivating juvenile Green Iguana gut faunas might help control or even eliminate introduced populations.

Acknowledgments.—This study was supported by NSF grants BNS 78-14196 and BNS 82-17569 to GMB, Smithsonian Scholarly Studies grants to ASR, and the Adopt your Logo project of Ecopetrol and the Instituto von Humboldt to BCB and VPP, and Smithsonian Exxon Fellowships that supported many of the field assistants. Thanks to our field assistants Barbara Allen Savitsky, Carlos Avila, Eric Castillo, Leo Fleishman, José Hin, Roberto Ibañez, Mathew Kramer, Maria Elena Leon, Lauri McHarque, Luis Paz, Vania de Silva Nunes, Frank Solis, and Katherine Troyer.

LITERATURE CITED

- Abts, M.L. 1987. Environment and variation in life history traits of the Chuckwalla, *Sauromalus obesus*. Ecological Monographs 57:215–232.
- Andrews, R.M. 1989. Intra-population variation in age of sexual maturity of the tropical lizard *Anolis limifrons* in Panama. Copeia 1989:751–753.
- Anderson, D.R., K.P. Burnham, and W.L. Thompson. 2000. Null hypothesis testing: problems, prevalence, and an alternative. Journal of Wildlife Management 64:912–923.
- Bock, B.C. 1984. Movement patterns relative to nesting site locations in a population of Green Iguanas (*Iguana iguana*) in Panama. Ph.D. Dissertation, University of Tennessee, Knoxville, Tennessee, USA. 139 p.
- Bock, B.C. 2014. *Iguana iguana* Linnaeus 1758. Common Green Iguana. IUCN SSC Iguana Specialist Group. Available from <http://www.iucn-issg.org/species/iguana-species> [Accessed 13 January 2015].
- Bock, B.C., and A.S. Rand. 1989. Factors influencing nesting synchrony and hatching success at a Green Iguana nesting aggregation in Panama. Copeia 1989:978–986.
- Bock, B.C., V.P. Páez, and A.S. Rand. 1998. Temperaturas del suelo atípicas en áreas comunales de anidación de la Iguana Verde (*Iguana iguana*) en Colombia y Panamá. Crónica Forestal y del Medio Ambiente 13:55–70.

- Bock, B.C., A.S. Rand, and G.M. Burghardt. 1985. Seasonal migration and nesting site fidelity in the Green Iguana. Pp. 435–443 *In* Migration: Mechanisms and Adaptive Significance. Rankin, M.A. (Ed.). University of Texas Marine Science Institute, Port Aransas, Texas, USA.
- Bock, B.C., A.S. Rand, and G.M. Burghardt. 1989. Nesting season movements of female Green Iguanas (*Iguana iguana*) in Panama. *Copeia* 1989:214–216.
- Burghardt, G.M. 2004. Iguana research: looking back and looking ahead. Pp. 1–6 *In* Iguanas: Biology and Conservation. Alberts, A.C., R.L. Carter, W.K. Hayes, and E.P. Martins (Eds.). University of California Press, Berkeley and Los Angeles, California, USA.
- Burghardt, G.M., and A.S. Rand. 1985. Group size and growth rate in hatchling Green Iguanas (*Iguana iguana*). *Behavioral Ecology and Sociobiology* 18:101–104.
- Burnham, K.P., and D.R. Anderson. 1998. Model Selection and Inference: A Practical Information-Theoretic Approach. Springer-Verlag, New York, New York, USA.
- Castanet, J. 1994. Age estimation and longevity in reptiles. *Gerontology* 40:174–192.
- Caswell, H. 2001. Matrix Population Models. Construction, Analysis, and Interpretation. 2nd Edition. Sinauer Associates, Inc. Publishers, Sunderland, Massachusetts, USA.
- Drummond, H. 1983. Adaptiveness of island nest-sites of Green Iguanas and Slider Turtles. *Copeia* 1983:529–530.
- Drummond, H., and G.M. Burghardt. 1982. Orientation in dispersing hatchling Green Iguanas, *Iguana iguana*. Pp. 271–291 *In* Iguanas of the World: Their Behavior, Ecology, and Conservation. Burghardt, G.M., and A.S. Rand (Eds.). Noyes Publications, Park Ridge, New Jersey, USA.
- Dugan, B.A. 1982. The mating behavior of the Green Iguana, *Iguana iguana*. Pp. 320–341 *In* Iguanas of the World: Their Behavior, Ecology, and Conservation. Burghardt, G.M., and A.S. Rand (Eds.). Noyes Publications, Park Ridge, New Jersey, USA.
- Dugan, B.A., A.S. Rand, G.M. Burghardt, and B.C. Bock. 1981. Interactions between nesting crocodiles and iguanas. *Journal of Herpetology* 15:409–414.
- Falcón, W., J.D. Ackerman, W. Recart, and C.C. Daehler. 2013. Biology and impacts of Pacific island invasive species. 10. *Iguana iguana*, the Green Iguana (Squamata: Iguanidae). *Pacific Science* 67:157–186.
- Fisher, R.A. 1930. The Genetical Theory of Natural Selection. Oxford at the Clarendon Press, Cambridge, United Kingdom.
- Fitch, H.S., and R.W. Henderson. 1977. Age and sex differences, reproduction, and conservation of *Iguana iguana*. Milwaukee Public Museum Contributions to Biology and Geology 13:1–21.
- Fitch, H.S., R.W. Henderson, and D.M. Hillis. 1982. Exploitation of iguanas in Central America. Pp. 397–416 *In* Iguanas of the World: Their Behavior, Ecology, and Conservation. Burghardt, G.M., and A.S. Rand (Eds.). Noyes Publications, Park Ridge, New Jersey, USA.
- García-Quijano, C.G., T.A. Carlo, and J.A. Arce-Nazario. 2011. Human ecology of a species introduction: interactions between humans and introduced Green Iguanas in a Puerto Rican urban estuary. *Human Organization* 70:164–178.
- Greene, H.W., G.M. Burghardt, B.A. Dugan, and A.S. Rand. 1978. Predation and the defensive behavior of Green Iguanas (Reptilia, Lacertilia, Iguanidae). *Journal of Herpetology* 12:169–176.
- Harris, D.M. 1982. The phenology, growth, and survival of the Green Iguana, *Iguana iguana*, in northern Colombia. Pp. 150–161 *In* Iguanas of the World: Their Behavior, Ecology, and Conservation. Burghardt, G.M., and A.S. Rand (Eds.). Noyes Publications, Park Ridge, New Jersey, USA.
- Henderson, R.W. 1974. Aspects of the ecology of the juvenile Common Iguana (*Iguana iguana*). *Herpetologica* 30:327–332.
- Hirth, H.F. 1963. Some aspects of the natural history of *Iguana iguana* on a tropical strand. *Ecology* 44:613–615.
- Iverson, J.B. 1979. Behavior and ecology of the rock iguana *Cyclura carinata*. *Bulletin of the Florida State Museum, Biological Sciences* 24:175–358.
- Iverson, J.B. 2007. Juvenile survival in the Allen Cays Rock Iguana (*Cyclura cyclura inornata*). *Copeia* 2007:740–744.
- Knapp, C.R., and J.G. Abarca. 2009. Effects of radio transmitter burdening on locomotor ability and survival of iguana hatchlings. *Herpetologica* 65:363–372.
- Lebreton, J.D., K.P. Burnham, J. Clobert, and D.R. Anderson. 1992. Modeling survival and testing biological hypotheses using marked animals: a unified approach with case studies. *Ecological Monographs* 62:67–118.
- López-Torres, A.L., H.J. Claudio-Hernández, C.A. Rodríguez-Gómez, A.V. Longo, and R.L. Joglar. 2011. Green Iguanas (*Iguana iguana*) in Puerto Rico: is it time for management? *Biological Invasions* 14:35–45.
- Meshaka, W.E., Jr., H.T. Smith, E. Golden, J.A. Moore, S. Fitchett, E.M. Cowan, R.M. Engeman, S.R. Sekscienski, and H.L. Cress. 2007. Green Iguanas (*Iguana iguana*): the unintended consequence of sound wildlife management practices in a south Florida park. *Herpetological Conservation and Biology* 2:149–156.
- Muñoz, E.M., A.M. Ortega, B.C. Bock, and V.P. Páez. 2003. Demografía y ecología de anidación de la Iguana Verde, *Iguana iguana* (Squamata: Iguanidae), en dos poblaciones explotadas en la Depresión Momposina, Colombia. *Revista de Biología Tropical* 51:229–240.
- Pasachnik, S.A., R. Carreras de León, V.H. Reynoso, E. Rupp, Y.M. León, and S.J. Incháustegui. 2012. Green Iguana (*Iguana iguana*) in the Dominican Republic. *IRCF Reptiles and Amphibians Conservation and Natural History* 19:1–3.

Herpetological Conservation and Biology

- Rand, A.S. 1968. A nesting aggregation of iguanas. *Copeia* 1968:552–561.
- Rand, A.S. 1984. Clutch size in *Iguana iguana* in central Panama. Pp. 115–122 *In* Vertebrate Ecology and Systematics. Segal, R.A., L.E. Hunt, J.L. Knight, L. Malaret, and N.L. Zuschlag (Eds.). University of Kansas Museum of Natural History, Lawrence, Kansas, USA.
- Rand, A.S., and B.C. Bock. 1992. Size variation, growth, and survivorship in nesting Green Iguanas (*Iguana iguana*) in Panama. *Amphibia-Reptilia* 13:147–156.
- Rand, A.S., and B.A. Dugan. 1980. Iguana egg mortality within the nest. *Copeia* 1980:531–534.
- Rand, A.S., and H.W. Greene. 1982. Latitude and climate in the phenology of reproduction in the Green Iguana. Pp. 142–149 *In* Iguanas of the World: Their Behavior, Ecology, and Conservation. Burghardt, G.M., and A.S. Rand (Eds.). Noyes Publications, Park Ridge, New Jersey, USA.
- Rand, A.S., and W.M. Rand. 1978. Display and dispute settlement in nesting iguanas. Pp. 245–251 *In* Behavior and Neurology of Lizards: An Interdisciplinary Colloquium. Greenberg, N., and P.D. MacLean (Eds.). National Institute of Mental Health, Rockville, Maryland, USA.
- Rand, A.S., and M.H. Robinson. 1969. Predation on iguana nests. *Herpetologica* 25:172–174.
- Rand, W.M., and A.S. Rand. 1976. Agonistic behavior in nesting iguanas: a stochastic analysis of dispute settlement dominated by the minimization of energy costs. *Zeitschrift für Tierpsychologie* 40:279–299.
- Rodda, G.H. 1992. The mating behavior of *Iguana iguana*. *Smithsonian Contributions to Zoology* 534:1–40.
- Rodda, G.H., B.C. Bock, G.M. Burghardt, and A.S. Rand. 1988. Techniques for identifying individual lizards at a distance reveal influences of handling. *Copeia* 1988:905–913.
- Rovatsos, M., M. Pokorná, M. Almanová, and L. Kratochvíl. 2014. Cretaceous park of sex determination: sex chromosomes are conserved across iguanas. [Biology Letters](https://doi.org/10.1098/rsbl.2013.1093) 10:20131093. doi:10.1098/rsbl.2013.1093
- Sexton, O.J. 1975. Black Vultures feeding on iguana eggs in Panamá. *American Midland Naturalist* 93:463–468.
- Slavens, F.L., and K. Slavens. 1999. Reptiles and Amphibians in Captivity: Breeding, Longevity, and Inventory. Woodland Park Zoological Gardens, Seattle, Washington, USA.
- Smith, H.T., E. Golden, and W.E. Meshaka, Jr. 2007. Population density estimates for a Green Iguana (*Iguana iguana*) colony in a Florida state park. *Journal of the Kansas Herpetological Society* 21:19–20.
- Smith, H.T., W.E. Meshaka, Jr., R.M. Engeman, S.M. Crossett, M.E. Foley, and G. Bush. 2006. Raccoon predation as a potential limiting factor in the success of the Green Iguana in southern Florida. *Journal of the Kansas Herpetological Society* 20:7–8.
- Stephen, C., S. Pasachnik, A. Reuter, P. Mosig, L. Ruyle, and L. Fitzgerald. 2011. Survey of Status, Trade, and Exploitation of Central American Iguanas. Report, Department of Interior, United States Fish and Wildlife Service, Washington, D.C., USA.
- Troyer, K. 1984a. Diet selection and digestion in *Iguana iguana*: the importance of age and nutrient requirements. *Oecologia* 61:201–207.
- Troyer, K. 1984b. Behavioral acquisition of the hindgut fermentation system by hatchling *Iguana iguana*. *Behavioral Ecology and Sociobiology* 14:189–193.
- van Devender, R.W. 1982. Growth and ecology of Spiny-tailed and Green Iguanas in Costa Rica, with comments on the evolution of herbivory and large body size. Pp. 162–183 *In* Iguanas of the World: Their Behavior, Ecology, and Conservation. Burghardt, G.M., and A.S. Rand (Eds.). Noyes Publications, Park Ridge, New Jersey, USA.
- Wallace, B.P., S.S. Heppell, L.L. Lewison, S. Kelez, and L.B. Crowder. 2008. Impacts of fisheries bycatch on Loggerhead Turtles worldwide inferred from reproductive value analyses. *Journal of Applied Ecology* 45:1076–1085.
- Werner, D.I. 1991. The rational use of Green Iguanas. Pp. 181–201 *In* Neotropical Wildlife Use and Conservation. Robinson, J.G., and K.H. Redford (Eds.). University of Chicago Press, Chicago, Illinois, USA.
- White, G.C., and K.P. Burnham. 1999. Program MARK: survival estimation from populations of marked animals. *Bird Study* 46(Supplement):120–138.
- Wiewandt, T.A. 1982. Evolution of nesting patterns in iguanine lizards. Pp. 119–141 *In* Iguanas of the World: Their Behavior, Ecology, and Conservation. Burghardt, G.M., and A.S. Rand (Eds.). Noyes Publications, Park Ridge, New Jersey, USA.
- Wikelski, M., V. Wong, B. Chevalier, N. Rattenborg, and H.L. Snell. 2002. Galápagos islands: Marine Iguanas die from trace oil pollution. *Nature* 417:607–608.
- Zug, G.R., and A.S. Rand. 1987. Estimation of age in nesting female *Iguana iguana*: testing skeletochronology in a tropical lizard. *Amphibia-Reptilia* 8:237–250.



BRIAN C. BOCK (left) obtained his Ph.D. in Ethology from the University of Tennessee, Knoxville, in 1984 and held Smithsonian, Fulbright, and AAAS fellowships before moving to Colombia, first as a professor at the Universidad Nacional de Colombia and now as a professor in the Instituto de Biología of the Universidad de Antioquia in Medellín, Colombia, where he teaches courses in conservation biology and behavioral ecology. He has edited three books and published over 60 scientific articles and book chapters. His initial research focused on how reptile movement patterns influence population structure, but he also has conducted studies on reptile nesting ecology and demography, as well as on the population genetics of other species of Colombian flora and fauna. (Photographed by Jessica Bock Páez).

VIVIAN P. PÁEZ (right) obtained her Ph.D. in Ecology, Ethology, and Evolution from Ohio University in 1995 and is currently a professor in the Instituto de Biología of the Universidad de Antioquia in Medellín, Colombia, where she teaches courses in population ecology and

herpetology. She has edited three books and published over 70 scientific articles and book chapters. Her research interests have focused on the influence of nest microclimatic conditions and paternal effects on different fitness components of turtles with temperature-dependent sex determination. She also is conducting demographic projects using population matrix models to permit the elaboration of management plans for several species of freshwater turtles. Since arriving in Antioquia, Colombia, she has been involved in a number of projects on the natural history and diversity of the herpetofauna in this region, including the founding of the Museo de Herpetología of the Universidad de Antioquia (MHUA). (Photographed by Jessica Bock Páez).



A. STANLEY RAND obtained his Ph.D. in Biology from Harvard University in 1961 and after two years working in Brazil he joined the staff of the Smithsonian Tropical Research Institute in Panamá, where he spent his career studying amphibian and reptile ecology. His research interests were in frog communication and sexual selection, but he also conducted pioneering work on Green Iguana biology, and co-edited the seminal 1982 *Iguanas of the World* volume. He produced over 150 scientific publications during his career and was the first recipient of the Henry S. Fitch Award for Excellence in Herpetology. Stan died on 14 November 2005. (Photographed by Dorothy White).



GORDON M. BURGHARDT obtained his Ph.D. in Biopsychology from the University of Chicago in 1966 and after teaching in Biology at the University of Chicago took a position in the Department of Psychology of the University of Tennessee, Knoxville, where he is currently Alumni Distinguished Service Professor in both the Psychology and Ecology and Evolutionary Biology departments. He has published or edited six books, including the seminal 1982 *Iguanas of the World* volume and published over 200 scientific articles and book chapters. His research employs field and laboratory studies using observational, experimental, and molecular genetics approaches to questions of ontogeny and chemoreception in reptiles. Predation, social behavior, mating, and antipredator behavior are studied. Snakes are typically employed because of his interest in the tongue-vomer nasal organ system. Another active area of interest is play behavior in “non-playing” taxa. He also has a continuing interest in the behavior of bears and humans, ethical treatment of animals, and theoretical and historical issues in ontogeny, and the historical antecedents of contemporary ethology, psychology, and sociobiology. (Photographed by Charles Votaw).